



E O N
L I T H I U M

EL5W

Charge your world



INVERTER SETUP GUIDE FOR MECER

EON Lithium batteries are fully compatible with Mecer inverters that have Modbus (RS485) communication capability. The setup guide will assist the installer with the correct configuration and setup of the inverter and battery.

Note: these settings only apply to one battery. For multiple batteries, please follow the instructions in the manual as well as the best practices for paralleling batteries.



Batt Model	Nominal V	Float V	Equalization/ Bulk V	Cutoff V	Recommended Charge Amps	Max Charge A
EL5W	51.2V	55.2V	55.2V	46V	25A	100A

- The comms cable will be plugged in at the RS485 port on the battery (not the cascading or parallel ports) to the Li-ION port on the inverter (Below the display).

BATTERY TYPE SETTING

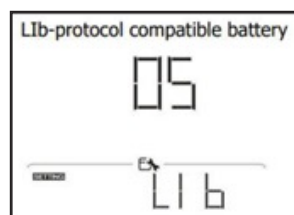

- On the inverter settings menu go to setting 5 for Battery Type setting. Select "Lib"

The recommended shutdown % is 20% as it will prolong the battery life and deliver optimal performance.

POWER AND COMMUNICATION CABLE CONNECTIONS

Power cables

- Check the rating of the inverter and the battery pack that will be working together. Make sure that the correct gauge cable is used and the correct fuse protection.
- If the power rating of the battery is lower than the inverter, then make sure the maximum discharge current is set to conform to the battery power rating.

Example:

- Inverter = 8kW (Max power is 8kW or 160A DC)
- Battery = 5kWh (Max power is 5kW or 100A DC)
- Set the maximum discharge current to 100A in the battery settings.
- For batteries connected in parallel, please see the best practices guide.

Communication cables

- The LI-ION port of the inverter to the RS485 port of the battery.
- The RS485 PIN outs are as follows:

PIN	Mecer RS485	Eon RS485
1	-	B
2	-	A
3	B	-
4	-	-
5	A	-
6	-	-
7	-	-
8	-	-

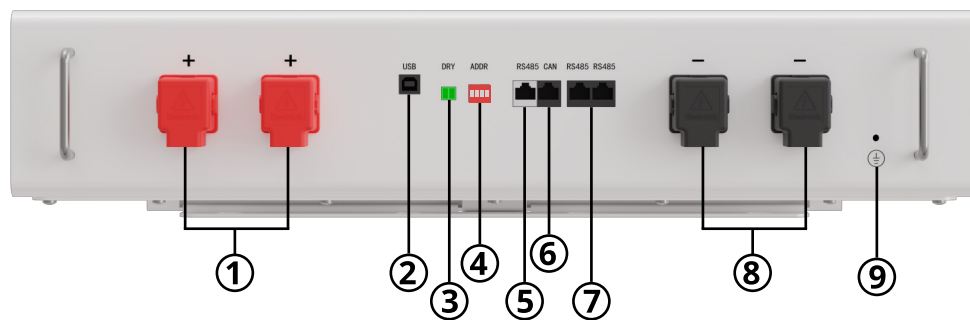
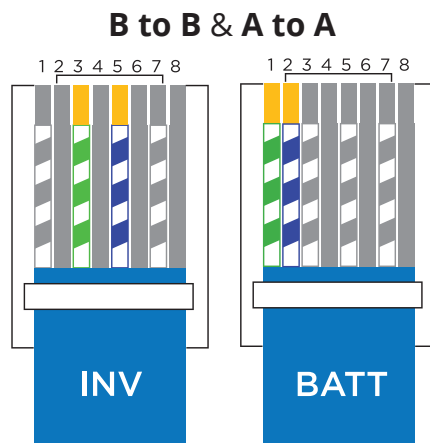

Item	Name	Definition
1	Positive Socket	Battery output positive or parallel positive line
2	USB	Communication cascade port - connects battery to host computer
3	Dry Contact	/
4	ADD	DIP switch
5	RS485	Communication cascade port - supports RS485 communication
6	CAN	Communication cascade port - supports CAN communication (factory default)
7	Parallel 1&2	Battery parallel connection ports
8	Negative Socket	Battery output negative or parallel negative line
9	Ground termina	Grounding device

Parallel or Multiple battery Installation - EON Lithium Dip switch settings

If you are using one battery, then set the DIP switches as the master or Battery 1. If you have multiple batteries in parallel, then follow the table below to set each battery accordingly. Also make sure to connect the supplied comms cable between the battery RS485 parallel ports (7 in figure below)

Address	Switch Position Codes			
	#1	#2	#3	#4
1 (Master)	OFF	OFF	OFF	OFF
2	ON	OFF	OFF	OFF
3	OFF	ON	OFF	OFF
4	ON	ON	OFF	OFF
5	OFF	OFF	ON	OFF
6	ON	OFF	ON	OFF
7	OFF	ON	ON	OFF
8	ON	ON	ON	OFF
9	OFF	OFF	OFF	ON
10	ON	OFF	OFF	ON
11	OFF	ON	OFF	ON
12	ON	ON	OFF	ON
13	OFF	OFF	ON	ON
14	ON	OFF	ON	ON
15	OFF	ON	ON	ON
16	ON	ON	ON	ON